

PAPER • OPEN ACCESS

Evaluating Cost-Effective Culture Media for Nutraceuticals Production from Microalgae Using Computer-Aided Large Scale Predictions

To cite this article: A Ibanez *et al* 2020 *J. Phys.: Conf. Ser.* **1655** 012082

View the [article online](#) for updates and enhancements.



IOP | ebooks™

Bringing together innovative digital publishing with leading authors from the global scientific community.

Start exploring the collection—download the first chapter of every title for free.

Evaluating Cost-Effective Culture Media for Nutraceuticals Production from Microalgae Using Computer-Aided Large Scale Predictions

A Ibañez, Y Rolon and G Gelves

Universidad Francisco de Paula Santander, Cúcuta, Colombia

E-mail: germanricardogz@ufps.edu.co

Abstract. The purpose of this research consist of microalgae biomass productivity prediction in a large scale plant from *Chlorella vulgaris* using SuperPro Designer software. Two culture media were evaluated to identify their potential use in large-scale processes: (a) the Bold Basal medium enriched with sodium acetate and (b) a growth medium for high cell density cultures proposed from references. Results found in this research suggest that simulated plant should reach a capacity to generate 1.4 kg/h of biomass at a cost of 1.44 USD/g using Bold Basal medium. In contrast, a productivity of 28 kg/h at a cost of 0.14 USD/g was found using a medium proliferation of highly dense microalgae cultures. These findings suggest that Bold Basal medium could negatively impact operating costs, limiting its use in large-scale processes regarding nutraceuticals production. Results found here demonstrate the potential usage of simulators for estimating costs and production which allows predicting the bioprocess feasibility.

1. Introduction

Nutraceuticals are biotechnological products composed of highly concentrated bioactive substances. These compounds are obtained after an isolation, concentration and purification process. Nutraceuticals generally have a therapeutic effect due to their nutritional composition [1]. In different countries, nutraceuticals are used for different purposes, but mainly their consumption is based on improving health and reducing heart disease risks like Alzheimer [2] and cancer [3]. Based on the latter, currently nutraceuticals dominate the health food market, as they are collectively worth many hundreds of millions of dollars [4]. Currently, sustainable cultivation systems development is based on parameters such as pH, temperature, light intensity and culture media concentration together with the modelling of upstream and downstream processes. The latter are main factors for achieving high metabolite production at industrial scale from microalgae organisms [5, 6]. However, suitable technological needs and high operating costs at large-scale are weakly studied. Therefore, development of nutraceuticals represents a great problem at industrial production [1]. During several years, microalgae cultures have been implemented in photo-bioreactors in order to achieve productions on an industrial scale [5]. However, microalgae are characterized by low production rate that negatively impacts operating costs. To address this problem, several researches have focused on proposing culture media modifications in order to achieve higher productivity [5]. Even, high density culture media for improving *Chlorella vulgaris* have been evaluated [7]. However, these studies have been performed at laboratory level. Therefore, its effect on viability is still considered a challenge on industrial scale for microalgae production companies, since it requires an infrastructure and a significant financial resource to confirm their findings.



SuperPro Designer software is a modelling tool used for the evaluation and optimization of integrated processes in a wide range of industries such as pharmaceutical, biotechnology and specialized chemistry [8]. It allows yield and cost predictions related to large-scale metabolite production. For this reason, this research is based on modelling an industrial scale simulation to determine culture media effect of on techno-economic feasibility regarding nutraceuticals purposes.

2. Methodology

For performing simulations in SuperPro Designer software culture media conditions, upstream and downstream unit operations are required. There are specified in this section.

2.1. Culture media and conditions

Two culture media evaluated by simulation in this investigation were: (a) BBM (Bold Basal Medium) supplemented with sodium acetate [5], and (b) a medium designed for highly dense *Chlorella vulgaris* cultures [7] enriched with a total concentration of 150 g/L (see Tables 1 and 2, respectively).

Experimental data were taken from the bibliography to be included in the simulations. Thus, a value of 3.4 g/L of biomass produced from the BBM medium and a growth time of 144 hours [5] were used. Similarly, experimental concentration of *Chlorella vulgaris* was defined according to [7]. They managed a value of 81 g/L of biomass in 66 hours of fermentation using a medium designed for highly dense cultures, according to experimental reports.

Table 1. BBM culture medium composition.

Nutrient	Concentration (mg/L)
C ₂ H ₃ NaO ₂	1640
NaNO ₃	166
K ₂ HPO ₄	367
NaNO ₃	249
MgSO ₄ ·7H ₂ O	74.7
NaCl	24.8
K ₂ HPO ₄	74.9
KH ₂ PO ₄	175.4
CaCl ₂ ·2H ₂ O	24.9
ZnSO ₄ ·7H ₂ O	8.8
MnCl ₂ ·4H ₂ O	1.4
MoO ₃	0.7
CuSO ₄ ·5H ₂ O	1.5
Co(NO ₃) ₂ ·6H ₂ O	0.4
H ₃ BO ₃	11.4
EDTA	4.9
KOH	31.0
FeSO ₄ ·7H ₂ O	4.9

Table 2. Culture medium composition for highly dense cultures.

Nutrient	Concentration (mg/100 g glucose)
MgSO ₄ .7H ₂ O	1570
Urea	9140
KH ₂ PO ₄	2110
CaCl ₂	69.4
ZnSO ₄ .7H ₂ O	11.1
MnCl ₂ .4H ₂ O	13
CoSO ₄ .7H ₂ O	9.7
CuSO ₄ .7H ₂ O	8
(NH ₄) ₆ Mo ₇ O ₂₄ .7H ₂ O	4.6
H ₃ BO ₃	28.5
FeSO ₄ .7H ₂ O	125.1

2.2. Operation mode

Industrial scale simulation carried out in SuperPro Designer v.10 was performed with proposed equipment and unit operations required for an industrial scale nutraceuticals production. Equipment and its operations tasks are presented below: (a) Stirrer tank: its purpose is homogenizing culture media species. (b) Heat sterilizer. allows the culture medium to be sterilized to avoid contamination in the inoculation train. (c) Airlift-type bioreactors: microalgae are grown for biomass production. (d) Storage tank: biomass previously produced in fermenters is stored. (e) Centrifugation: was performed in order to sediment and separate biomass from the impurities. (f) Rotary drum filter: centrifugation remnants are removed in order to produce a more concentrated biomass. (g) Lyophilizer: a drying process is carried out for removing water from biomass. (h) Packaging equipment: final product encapsulating.

2.3. Up-Stream

All fermentations on an industrial scale are governed by Up-Stream processing consisting of four main areas: culture media preparation, heat sterilization, inoculation and fermentation [9]. For the Up-Stream processing, culture media preparation in a shaking tank is performed. Then, culture media pass through a heat sterilizer in order to eliminate all kinds of impurities or contaminating agent. Afterwards, an inoculation train to the Air Lift Fermenters are implemented (see Figure 1).

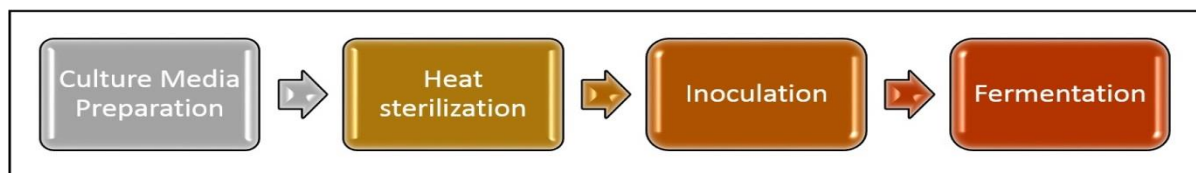
**Figure 1.** Large scale *Chlorella vulgaris* production. Upstream processing.

2.4. Down-Stream

In order to concentrate the biomass produced from previous fermenters, down-stream processing (see Figure 2) was carried out, starting with a centrifugation to settle and separate biomass from possible impurities. Subsequently, biomass sediment is treated in a rotating drum filter to concentrate and eliminate those remnants resulting from the centrifugation process. Then, biomass is pumped to a freeze dryer for removing water. Finally, *Chlorella vulgaris* is packaged in 250 mg tablets.

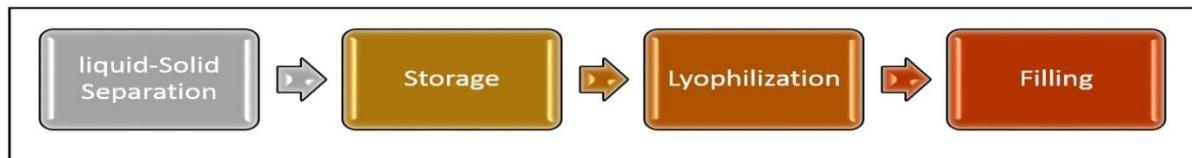

Figure 2. Large scale *Chlorella vulgaris* production. Downstream processing.

3. Results and Discussions

The main goal of paper consists on the evaluation of profitable culture media for nutraceutical products from *Chlorella vulgaris* microalgae using the SuperPro Designer computational tool. Simulated result regarding BBM culture medium evaluation (see Figure 3) suggests a biomass production of 1.4 kg/h. In contrast, a productivity of 28 kg/h was found using a high-density *Chlorella* medium.

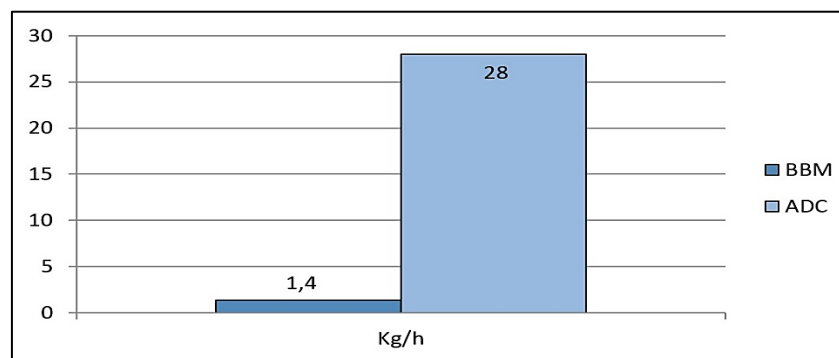

Figure 3. Estimation of productivity resulted from culture media evaluated: BBM and ADC (High Cell Proliferation).

Figure 4 shows the upstream and downstream process diagram for implemented SuperPro Designer simulations. The plant is operated at continuous mode in closed systems (photobioreactors) since, according to [10] these systems have higher productivity and less contamination, allowing control of growing conditions. The closed system implementation at a large scale determines the operating costs, which makes them relatively high. Fortunately, these problems can be overcome with appropriate engineering solutions using computer-aided techniques. Based on the above, SuperPro Designer simulator was used in this research and a plant was designed to obtain nutraceuticals and its productivity was evaluated. Unit operations were proposed based on experimental data and bibliographic references [6, 7] on a laboratory scale (see Figure 4 and Table 3).

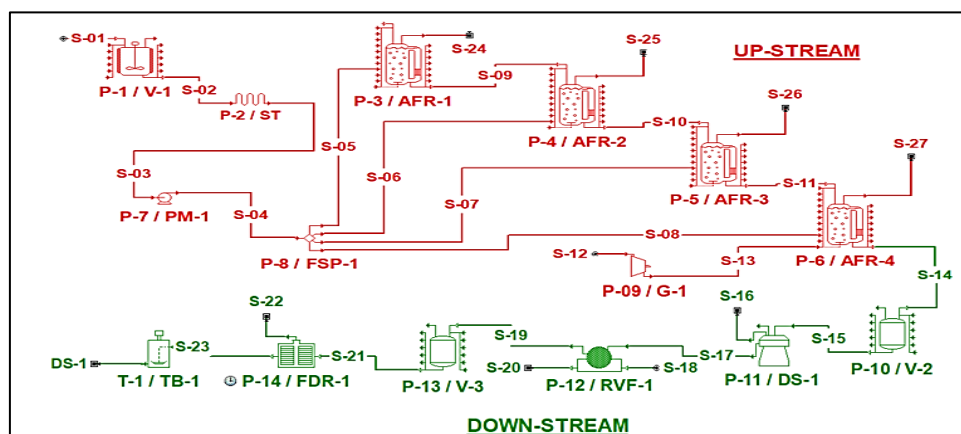

Figure 4. Industrial scale simulation of large scale nutraceuticals microalgae in SuperPro Designer.

Table 3. Unit operation nomenclature list used in implemented simulations.

Name	Equipment
P-1 / V-1	Blending
P-2 / V-2	Heat Sterilization
P-3 / ARF-1	Air Lift Fermentation
P-4 / ARF-2	Air Lift Fermentation
P-5 / ARF-3	Air Lift Fermentation
P-6 / ARF-4	Air Lift Fermentation
P-7 / PM-1	Fluid Flow
P-8 / FSP-1	Flow Splitting
P-9 / G-1	Gas Compression
P-10 / V-2	Storage
P-11 / DS-1	Centrifugation
P-12 / RVF-1	Rotary Vacuum Filtration
P-13 / V-3	Storage
P-14 / FDR-1	Freeze Drying
T-1 / TB-1	Tableting

The economic feasibility of a nutraceutical product is defined by large-scale operating costs determination. Experimental implementation at the industrial level is a typical way for determining this fundamental stage that consists in the estimation of raw materials usage, productivity achieved and the necessary investment resources. However, the aforementioned requires the necessary infrastructure, significant experimentation time and a risk capital dedicated exclusively to research. As mentioned earlier, these needs can be determined by computational simulation with the use of computer-aided design.

According to simulation results in SuperPro Designer, the annual costs associated with *Chlorella vulgaris* production from BBM culture medium are estimated at 16 million dollars. The percentage of these costs is discriminated (see Figure 5) in required raw material, utilities, labour, waste treatment, laboratory costs and installation costs necessary for the plant establishment. At the same time, when using a medium for proliferation of highly dense cultures, a total cost of 32 million dollars per year is determined. This increase in costs is due to a greater extent to the high requirement of raw materials (see Figure 6, compared to the BBM medium. However, as mentioned above, the productivity obtained is significantly high in contrast to the BBM medium.

Currently, in the world nutraceutical market, there is a great variety of commercial products. Green foods, my-superfoods and fresh-health-care stand out in amazon web site among others. These products represent a benefit in people's health and also diseases prevention [11]. These metabolites are normally traded on the market with values ranging from \$ 0.10-0.23 USD/gram. Taking this information into account, the BBM culture medium for nutraceuticals production from *Chlorella vulgaris* microalgae has a negative effect on operational costs since very low productivity is obtained. This means that each gram of nutraceutical product has a cost of 1.44 USD/g using BBM medium with a production size (bioreactor) of 150 m³.

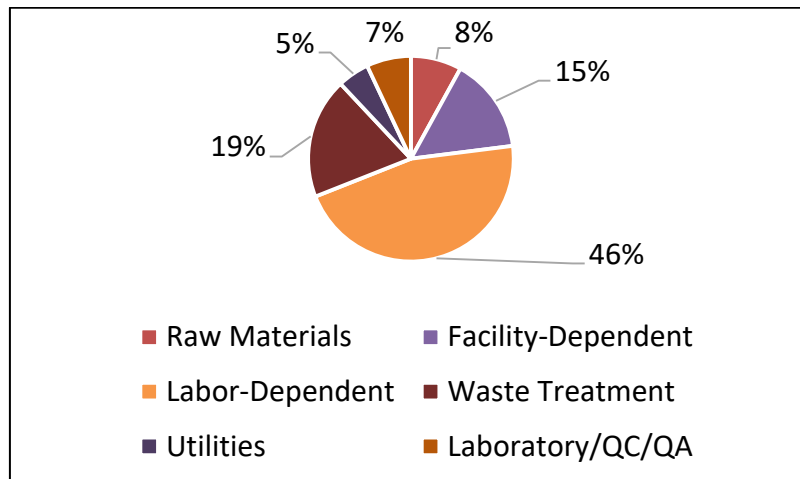

Figure 5. Annual operating costs regarding BBM culture media.

With reference to the highly dense culturing medium [7], costs obtained are estimated at 0.14 USD/g. The above, suggests that these values can be competitive in market. On the other hand, the use of a proliferation medium for highly dense cultures could be a great strategy to obtain nutraceutical products on a large scale. The above, taking into account its operating costs. An additional finding found in this research, which can be attributed to the medium of high cell proliferation, refers to the equipment size reduction required on an industrial scale. This is supported by the re-dimensioning of Airlift-type bioreactors, which, according to the results, the new production size is estimated at around 30 m³. This 80% size reduction related to fermenters can be explained by the residence time or hydraulic retention time of the equipment. It refers to the time required for each incoming particle to travel through the reactor assuming complete mixing. According to experimental data, a time of 144 hours is required for the BBM medium [5], while the reports for the highly proliferating medium suggest a value of 66 hours, respectively. Therefore, in the latter, the size required for the mentioned value to be reached is less than that estimated in the BBM medium.

In Figure 6, the percentages that represent the utilities, waste treatment, labour, laboratory costs, raw material and installation cost are shown, with reference to the medium of high proliferation. When comparing these percentages with those obtained in Figure 5, it can be deduced that the labour staff decreased from 46% to a value of 23%. The above, because as mentioned above, the equipment size was significantly reduced.

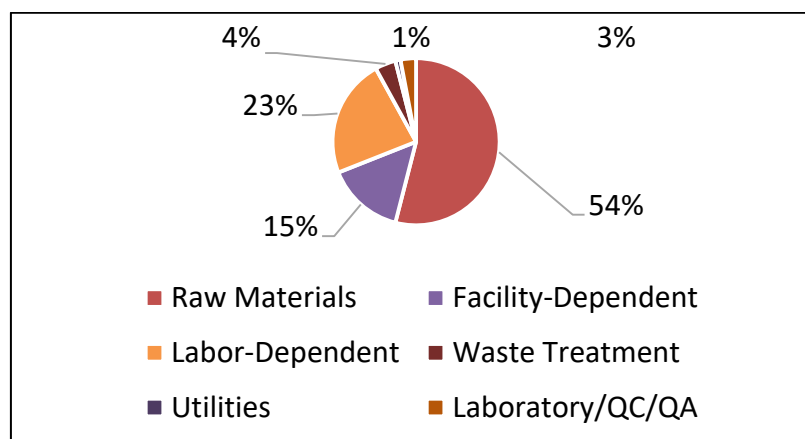

Figure 6. Annual operating costs resulted for ADC medium (highly dense culturing medium).

Therefore, the costs associated with hiring personnel are also low. However, raw material costs increased significantly from 8% to 54% (see Figure 7). This is because glucose has a high market value at a cost of USD 36/kg and sodium acetate, which is the raw material for simulation with the BBM medium, has a value of USD 18/kg. It is worth mentioning that the raw material costs were provided from the supplier Sigma Aldrich web site.

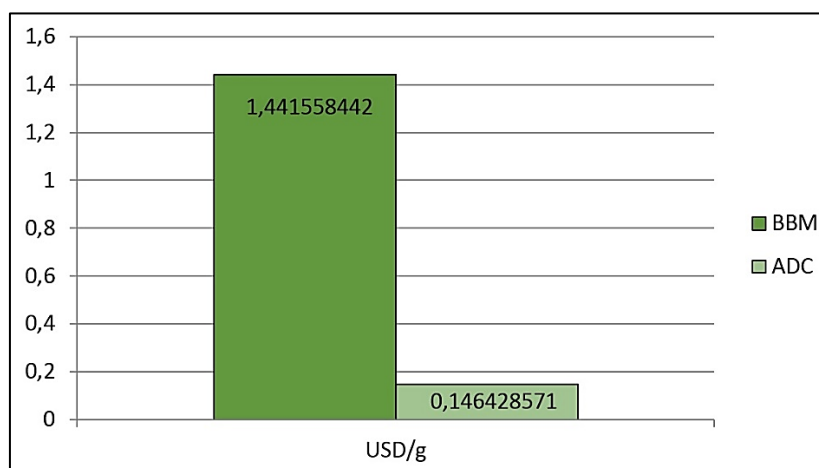

Figure 7. Comparison of nutraceuticals unit cost from SuperPro Designer simulations(USD/g).

According to the results obtained, the proposed plant has the capacity to produce 443 million 250 mg capsules per year (18 million bottles/year could be obtained).

Each with 240 capsules that could be marketed at a value of 26 USD. The above with a possible estimated profit of approximately \$ 16 million dollars.

4. Conclusions

Two culture media for nutraceuticals on an industrial scale from *Chlorella vulgaris* were evaluated using the SuperPro Designer computational tool. According to the results obtained by simulation, the use of a culture medium to obtain high cell densities could generate promising estimates for nutraceutical metabolites production of industrial interest in terms of economic feasibility. The results obtained in this investigation demonstrate the great utility of a simulator such as SuperPro Designer, which offers an estimate of the costs and productions necessary to know the pre-feasibility of a bioprocess and a subsequent plant materialization.

References

- [1] Malagón M, Corzo R and Manrique I 2017 Uso potencial de fitoquímicos derivados de microalgas para la obtención de nutraceuticos *Fundación Universidad de América Semilleros Formación Investigativa* **3(1)** 91
- [2] Shahidi F 2009 Nutraceuticals and functional foods: whole versus processed foods *Trends in Food Science & Technology* **20(9)** 376
- [3] Paniagua J 2015 Microalgal nutraceuticals *Handbook of marine microalgae Academic Press* **1** 255
- [4] Mobin S, Chowdhury H and Alam F 2019 Commercially important bioproducts from microalgae and their current applications-A review *Energy Procedia* **160** 752
- [5] González Á, Barajas A and Ardila A 2017 Producción de biomasa y proteínas de *Chlorella vulgaris* Beyerinck (Chlorellales: Chlorellaceae) a través del diseño de medios de cultivo selectivos *Ciencia & Tecnología Agropecuaria* **18(3)** 451

- [6] Brigagão G, Wiesberg L, Pinto J, Araújo F and Medeiros J 2019 Upstream and downstream processing of microalgal biogas: Emissions, energy and economic performances under carbon taxation *Renewable and Sustainable Energy Reviews* **112** 508
- [7] Doucha J and Lívanský K 2012 Production of high-density *Chlorella* culture grown in fermenters. *Journal of applied phycology* **24(1)** 35
- [8] Thomsen T, Hauggaard H, Bruun E and Ahrenfeldt J 2011 The potential of pyrolysis technology in climate change mitigation—influence of process design and—parameters, simulated in SuperPro Designer Software *Roskilde: Danmarks Tekniske Universitet, Risø Nationallaboratoriet for Bæredygtig Energi, Denmark. Forskningscenter Risoe. Risoe-R* **1** 1764
- [9] Mukherjee S 2019 Isolation and purification of industrial enzymes: advances in enzyme technology *Advances in Enzyme Technology* **1** 41
- [10] Matos Â, Ferreira W, Morioka L, Moecke I, França K and Sant'Anna E 2018 Cultivation of *Chlorella vulgaris* in medium supplemented with desalination concentrate grown in a pilot-scale open raceway *Brazilian Journal of Chemical Engineering* **35(4)** 1183
- [11] García E 2018 Nutracéuticos una opción para la salud en el siglo XXI. *Revista Científica Conecta Libertad* **2(1)** 1