

Optimization of the auxiliary ventilation system, based on experiments executed on a ventilation test bench for mines

Yesid Castro-Duque

Grupo de Investigación en Tecnología Cerámica GITEC. Universidad Francisco de Paula Santander, Cúcuta, Colombia. yesidcd@ufps.edu.co

Received: April 23th, 2017. Received in revised form: May 28th, 2018. Accepted: July 6th, 2018

Abstract

In this study, the simulation results of the parameters concerning mine ventilation on a test bench are presented. Said investigation incorporated the previous design and implementation of a monitoring system at the laboratory. This was in order to calculate the fan efficiency, based on electrical measurements, and fluid mechanics (Bernoulli theory), and whose results can be observed in real time on a computer or through other similar means. The designed system monitors parameters present in the atmosphere of the test bench's duct, such as temperature, air pressure, methane gas concentration, and electrical variables like voltage and current. The aforementioned observation is done through a graphical interface designed with LabView 2011 software. Tests were performed varying the accessories. The reduction percentage, allows one to infer that the duct section was adequately designed.

Keywords: fan performance; ventilation bench; temperature; humidity, pressure.

Optimización del sistema de ventilación auxiliar, basado en experiencias realizadas en un banco de pruebas de ventilación para minas

Resumen

En este Trabajo se presentan los resultados de la simulación, en un banco de pruebas, de los parámetros climatológicos y físicos; que influyen en la ventilación de minas. Previo a este artículo, se realizó el diseño e implementación de un sistema de monitoreo, para calcular la eficiencia del ventilador; teniendo en cuenta parámetros físicos, y de mecánica de fluidos (teoría de Bernoulli). La simulación se puede observar en tiempo real en un ordenador u otros medios similares. El sistema diseñado monitoriza parámetros presentes en la atmósfera del ducto del banco de pruebas, tales como: temperatura, presión del aire y la concentración de gas metano; además, se pueden observar variables eléctricas como voltaje, corriente, y frecuencia del motor. Este seguimiento se realiza a través de una interfaz gráfica diseñada con el software LabVIEW 2011. Se realizaron pruebas, variando accesorios del conducto del aire, condiciones ambientales, y velocidad del eje motriz. El porcentaje de reducción de las pérdidas muestra claramente que, cuando la sección del ducto está diseñada correctamente, se puede lograr ahorro de energía.

Palabras clave: rendimiento del ventilador; banco de ventilación; temperatura; humedad; presión.

1. Introduction

Ventilation is one of the main services used in underground mining, especially in coal mines. These mines have been submitted to great tragedies associated with faults, and erroneous designs in the main and auxiliary ventilation systems.

“Working conditions and safety depend on the ability of the ventilation system to remove hazardous contaminants such as dust and gases” [1]. Good fan performance is necessary to introduce enough fresh air into the underground mine, and thus regulate temperature and air humidity [2]. In addition to the airflow and load losses, there are some variables to consider, such as accessories (ducts, assemblies,

How to cite: Castro-Duque, Y., Optimization of the auxiliary ventilation system, based on experiences performed in a ventilation test bench for mines. DYNA, 85(207), pp. 208-213, Octubre - Diciembre, 2018.

etc.), and the variation of the motor frequency; all of which influence the optimization of an auxiliary ventilation system [3].

The auxiliary ventilation is carried out by bringing air to the work fronts, as the track is advanced, the amount of air that reaches the front gradually decreases due to the greater resistance of the conduit and the increase of the leaks (Vutukuri, 1984). Complete elimination of air leaks from, or to the duct system is impossible due to the duct quality and numerous joints in the duct system [4]. Taking into account the aforementioned, it is necessary to optimize the auxiliary ventilation systems, that is, with the implementation of anti-explosion fans and adequate conduits, and bear in mind the tests executed in the laboratories.

The contribution of fan power to total energy consumption is significantly responsible for a large percentage of total operating costs [5]. Ventilation systems can represent between 25% to 40% of the total energy costs and 40% to 50% of the energy consumption of a mining operation [6]; in addition, it has been demonstrated with the help of the Atkinson equation, that reducing the diameter of the conduit indicates the greatest cost in the power of the fan. It has also been shown that a leaking duct has a unique system characteristic, but a leaking duct has two. The first is that which compensates for the volume and pressure increases caused by the leak; the second is a characteristic for the discharge of flow at the end of the duct [7].

“Engineering design procedures for ventilation systems are well established. In particular, Jorgensen (1983) and McPherson (1993) provide detailed engineering design methodologies specific for mine ventilation systems and fan assemblages. Equations and design factors for estimating pressure losses for different airway geometries are introduced by these authors. Unfortunately, specific scientific work on the optimization of main mine fan assemblage installations (not necessarily the fans themselves) is very limited” (Stachulak and Mackinnon, 1980) [6].

In the coal mining department of Norte de Santander, Colombia, the auxiliary ventilation systems operate at a constant speed, so that costs are increased; the airflow required is low, compared to what is supplied. Similarly, the ducts used and the connections with accessories are not ideal, as they increase pressure losses. Correspondingly, the diameters of the ducts are small, between 40cm and 60cm, reducing systems efficiency.

The monitoring systems have increased the level of safety by allowing continuous observation of gases and temperatures in the mines. This permits the generation of early warnings when there are adverse or dangerous conditions. The continuous advances in ventilation technology will help to increase the safety of miners, as long as the engineers do not lose sight of the fundamental principles of ventilation. [8.9]

Given the aforesaid information, they were performed a series of simulations which can serve as a basis for optimizing the auxiliary ventilation system in underground mines; to accomplish this, a ventilation test bench was used, located in the Francisco de Paula Santander University in Cúcuta, Colombia. This article is the result of the analysis of

Table 1.
Permissible limits of common gases in underground mines

Gas		Permissible Limit
Carbon dioxide	CO2	5000 ppm
Carbon monoxide	CO	25 ppm
Hydrogen sulfide	H2S	1 ppm
Sulfur dioxide	SO2	0.25 ppm
Nitric Oxide	NO	25 ppm
Nitrogen dioxide	NO2	0.2 ppm

Source: Adapted from [11]

Table 2.
Permanence time of workers according to the effective temperature

Effective temperature	Stay time in hours
28	Without limits
29	6
30	4
31	2
32	0

Source: Adapted from [11]

parameters related to fan performance, used in one testing bench. Through the test bench, parameters such as temperature, pressure, the presence of methane (CH4), electric current and voltage are measured. The graphic programming was made using the LabVIEW 2011 software; this software is a graphical programming platform that helps progress from design to testing. The basic scheme of the structure consists of sensors, a signal processing circuit of a data acquisition card (DAQ) and a computer. The System has a frequency inverter, which increases or decreases the air speed according to requirements of flow, gas dilution, or temperature decrease. The ventilation test bench is equipped with tools and technology, for use in the development of academic research and for improving mine safety. [10]

1.1. Legal regulations of Colombian mining

Article 38 of decree 1886 of 2015, safety regulation in underground work, considers an appropriate mining atmosphere to have a 19.5% concentration of oxygen. Table 1 shows the permissible limits of frequent gases in underground mines (article 39 of decree 1886).

Table 2 defines the dwell times of the personnel according to the effective temperature of the air (Article 218 of decree 1886 of 2015).

2. Methodology

2.1. Pressure, velocity and air flow

The Pitot tube is used as an element to measure pressures (total, static, and dynamic); in order to obtain the velocity and airflow, the Bernoulli theory is used. The ventilation test bench is outfitted with sensors to perform measurements of the parameters previously indicated

“The accurate measurement of both air velocity and volumetric airflow can be accomplished using a Pitot tube, a differential pressure transducer, and a computer system which includes the necessary hardware and software to convert the raw transducer signals into proper engineering

units. The incorporation of sensors to measure the air temperature, barometric pressure, and relative humidity can further increase the accuracy of the velocity and flow measurements. The Pitot tube measures air velocity directly by means of a pressure transducer which generates an electrical signal, proportional to the difference between the pressure generated by the total pressure and the still air (static pressure). The volumetric flow is then calculated by measuring the average velocity of an air stream passing through a passage of a known diameter. When measuring volumetric flow, the passage of a known diameter must be designed to reduce air turbulence as the air mass flows over the Pitot tube. Also, the placement of the Pitot tube in the passage will influence how accurately the measured flow tracks the actual flow through the passage. Calibrating the measurement system in a wind tunnel can further increase the accuracy of the velocity and the flow measurements” [12].

The Bernoulli theory can be adopted as basis for developing results on the bench and generally in a mines ventilation system [2]. Using an analogous or digital manometer and with the help of the Pitot tube, measures such as pressure, total, static and dynamic were performed; the air speed can be calculated with eq. (1).

$$v = \sqrt{\frac{2P_d}{\rho}} \quad (1)$$

Where, v is air velocity in m/s, P_d is dynamic pressure in Pa, and ρ is air volumetric mass in Kg/m³.

The air density can be calculated, [2] with dry temperature and atmospheric pressure eq. (2).

$$\rho = \frac{0.455P_b}{273+T_d} \quad (\text{Kg/m}^3) \quad (2)$$

Where, T_d dry temperature in °C, and P_b in mm.C. Hg. Afterwards, the amount of air can be calculated with eq. (3).

$$Q = sv \quad (\text{m}^3/\text{s}) \quad (3)$$

Where, S is the air duct section in m².

2.2. Fan efficiency

The motor efficiency (n) of the motor can be calculated, with total power (P_u) in Kw, and absorbed energy (P_a) in Kw, [2] eq. (4).

$$n = \frac{P_u}{P_a} 100 \quad (\%) \quad (4)$$

The Total power of the motor can be calculated with total pressure in kgf/m²., and total air flow in m³/s. eq. (5).

$$P_u = \frac{Ht Q}{102} \quad (\text{Kw}) \quad (5)$$

The absorbed power can be calculated by means of eq. (6).

$$P_a = \frac{VI \text{Cos } \phi \sqrt{3}}{1000} \quad (\text{Kw}) \quad (6)$$

Where, V is voltage in V, I is current in A, and $\text{Cos } \phi$ is dimensionless power factor.

2.3. Design and optimization of the test bank

“The design and optimization of the test bench is focused on the analysis of parameters such as temperature, pressure, presence of methane (CH₄), electrical current and voltage. The software used for developing the monitoring system is LabVIEW 2011; this software is a graphical programming platform that facilitates the progress from design to test. The basic outline of the structure consists of sensors, a signal processing circuit of a data acquisition card and a computer as is shown in Fig. 1. The following sensors were used in the system: ACS712 for current, LM35 for temperature, MPXV5004DP for pressure, MQ4 to detect Methane (CH₄); as a sensor for measuring the voltage, one step-down transformer was used. The NI USB 6008 data acquisition card (DAQ) is chosen, as it provides a basic functionality for applications such as simple data logging, portable measurements, and academic lab experiments. This card has 12 channels of analog input and two analog output channels with a sampling rate of ten kS / s. The centrifugal fan was replaced by a Blower or G2D180-AE02-01 manufactured by EBM-Papst Industries Inc. (220/280 V, 50 Hz, 415W, 2350 rpm)”. [10]

The monitoring system, can be observed on a computer or any other similar equipment Fig. 2.

3. Results and discussion

3.1. Fan efficiency n

Fan efficiency improves as the frequency increases; however energy consumption is high, as the frequency is high Fig. 3. The frequency inverter is useful to rationalize energy consumption, since the system sends a signal to decrease the

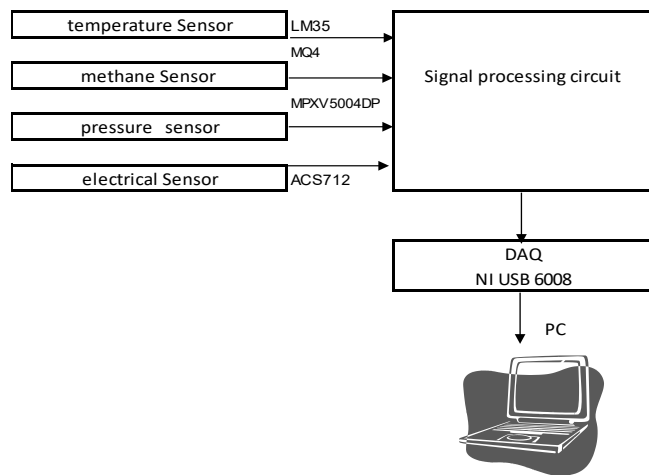

Figure 1 .System structure. Source: Adapted from [2]



Figure 2. Digital Control Panel.
Source: The author.

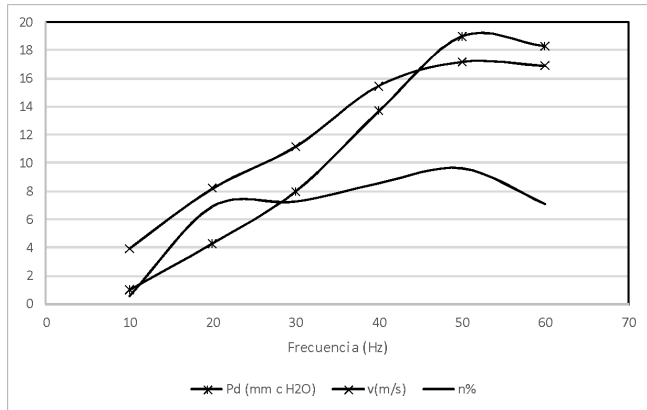

Figure 3 Motor efficiency, n, dynamic pressure, Pd and air speed, v, under different frequencies.
Source: The author.

flow, according to the needs. Weather conditions in the laboratory were: 28 °C dry temperature, 63% relative humidity of air, 732 mmHg barometric pressure and 1.1 Kg/m³ air density.

It is observed that the different parameters slightly decrease from 50 HZ, stabilizing at 60 HZ, the maximum frequency with which the system operates. The aforementioned is due to the pumping effect the system while generating maximum pressure on the walls of the pipeline; this effect is also called cavitation.

3.2 Total pressure losses

“The fan head (Ht) or its Total pressure compensates for losses through an entire air distribution system. The system pressure loss is proportional to the total system resistance coefficients (R) and to the airflow rate squared (Q²). The airflow rate (Q) is a given input. The system resistance coefficient is determined by the following two factors:

Friction pressure losses and local pressure drops caused by bends or other fittings on ducts” [13].

“When a ventilation duct in an area of development is extended, as the face advances, the quantity of air that comes, gradually decreases due to both the increasing resistance of the duct and the growing leakage” [14]. “Because of the nature of the pipes and the numerous joints, the complete

elimination of leakage from or into the duct line is impossible in practice” [4]; the aerodynamic increased resistance, generates pressure losses. “In text books on fluid mechanics, shock losses are often referred to in terms of the loss or drop in total pressure. This, in turn, is expressed in terms of ‘velocity pressure or head’” (McPherson, 1993) [6].

Total losses of pressure were analyzed, varying the length of the duct; where: L1 is 45cm =1, L2 = 2L1=2 and so on. Weather conditions in the laboratory were: 29°C dry temperature and relative humidity of 78%, frequency 60 Hz. Fig. 4 illustrates that at greater numbers of joints, pressure losses are more significant.

Similarly, if the number of joints is reduced, performance increases. The assembly is performed by placing a section, equivalent to two L1; performance increases by 4%. Table 3 highlights the parameters of evaluation: voltage 220V, current 1.4A, HR=90%, Ts=26.5°C, ρ=1.11Kg/m³, 60Hz frequency.

3.2. Elbow shock losses.

“Shock loss factors (X) may be defined as the number of velocity heads that give frictional pressure loss due to turbulence at any bend, variation in cross sectional area or any other configuration that causes a change in the general direction of airflow. (McPherson, 1993) [6]. Elbow shock losses can be calculated from the velocity head, $H_x \text{ elbow} = X \cdot H_v$ where, $H_x \text{ elbow}$ is the shock loss (Pa), H_v is the velocity head (Pa), and X is a shock loss factor (dimensionless). Values of shock factor for different types of elbow geometries are listed in standard ventilation design publications (Jorgensen, 1983; McPherson, 1993)” [6].

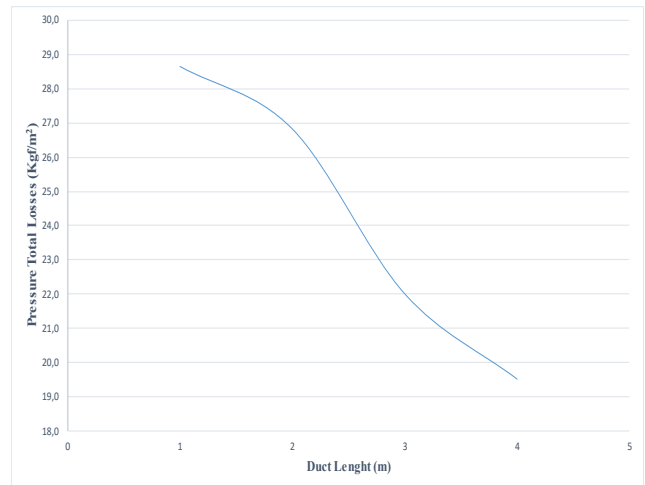

Figure 4. Pressure total losses
Source: the author

Table 3.
Performance by unions

Union	Hv (Pa)	v (m/s)	Q (m3/s)	n%
2L with union	217	62	0.62	31
2L without union	226	63.5	0,65	35

Source: The author

Table 4.
Head losses for elbow section. 60 Hz Frequency

Elbow	Hv (Pa)	X	Hx (Pa)	Reduction %
Straight	196	0.6	118	
Rounded	167	0.4	67	43

Source: the author

Table 5.
Pressure loss by section obstructions

Obstruction	Hv (Pa)	X1	Hx (Pa)	Reduction %
Square orifice	39	38.4	1506	
Circular orifice	33	10.5	346.5	78

Source: the author

Table 6.
Pressure loss by section obstruction

Obstruction	Hv (Pa)	X1	Hx (Pa)	Reduction %
Square orifice	39	38.4	1506	
Circular orifice	33	10.5	220	85

Source: The author



Figure 5. Test gas control. Measure of methane gas.
Source the author.

In the ventilation bench, the shock losses, with straight elbows were determined, and they were compared with shock losses, generated when they use rounded elbows. Table 4 presents a summary of results. The reduction percentage of losses clearly shows that when the elbow section is properly designed, an energy saving, of approximately 43% can be achieved, when the frequency is 60 Hz. Weather conditions in the laboratory were: 29°C dry temperature and relative humidity, 62%.

3.3. Obstructions. Circular and square orifices

Shock loss factor X_1 , when there are obstructions (doors or other elements) [15] is calculated with eq. (8).

$$X_1 = \frac{1}{cc^2} \left\{ \left[\frac{A_1}{A_2} \right]^2 - 1 \right\} \quad (8)$$

Through the ventilation bench, the shock losses, using

square orifice, were determined, and were compared with shock losses, generated when a circular orifice was used. Table 5 presents a summary of results. The reduction percentage of the losses clearly shows that, when the section is properly designed, an energy saving, of approximately 78% can be achieved, when the frequency is 60 Hz. Weather conditions in the laboratory were: 29°C dry temperature and relative humidity of 62%.

3.4. Venturi tube and square orifice

A comparison was made of the losses generated by a square regulator against those generated by the Venturi Tube. Table 6 is a summary of test results; the reduction percentage of the losses allows one to infer that the section was adequately designed. With this test, energy saving of approximately 85% can be achieved, when the frequency is 60 Hz. Weather conditions in the laboratory were: 30°C dry temperature and its relative humidity, 74%.

The methane monitoring system is simple; the bench has a sensor, which activates an alarm that is displayed on the digital control panel Fig. 5.

4. Conclusions

With the automation of the test bench, students and researchers may perform simulations of parameters related to an underground atmosphere. The implemented virtual instrumentation serves for testing, based on the real needs of a mine. These tests will be used to optimize the ventilation system of any underground mine. The installed monitoring system provides real-time signals which in turn become early warnings. The measurements and results can be seen in any medium similar to the computer. Aside from the reliability and effectiveness of the test, the automation can be improved due to the delivery speed of results provided by the system.

The ventilation bench becomes a practical tool model, to be implemented in underground mines, in order to improve safety.

The test bench has an MQ4 sensor for the detection of CH₄; the test was performed by injecting a 2% methane gas mixture. These gases are encapsulated in a cylinder used for the calibration of gas detectors (industrial scientific gas calibration). This test showed the dilution of the gas in a 5 second time period.

In this case, if the number of the duct unions is reduced, performance increases by 4%.

When the elbow section is properly designed (rounded), an energy saving, of approximately 43%, can be achieved.

When one obstruction presents one circular orifice, an energy saving, of approximately 78% can be achieved. This may be applied to orifices of air flow regulation doors.

If the section reduction is gradually performed through a venturi tube, there may be 85% energy savings.

If the duct accessories are properly designed, using engineering principles (Bernoulli and Atkinson laws), a ventilation system can operate efficiently.

References

- [1] Parra, M.T., Villafruela, J.M., Castro, F. and Mendez, C., Numerical and experimental analysis of different ventilation systems in deep mines. *Building and Environment*, 41(2), pp. 87-93, 2006.
- [2] Li, M. and Wang, X.R., Performance evaluation methods and instrumentation for mine ventilation fans. *Mining Science and Technology (China)*, 19(6), pp. 819-823, 2009.
- [3] Diego, I., Torno, S., Torano, J., Mendez, M. and Gent, M., A practical use of CFD for ventilation of underground works. *Tunnelling and Underground Space Technology*, 26(1), pp. 189-200, 2011.
- [4] Onder, M., Sarac, S. and Cevik, E., The influence of ventilation variables on the volume rate of airflow delivered to the face of long drivages. *Tunnelling and Underground Space Technology*, 21(5), pp. 568-574, 2006.
- [5] Chatterjee, A., Zhang, L. and Xia, X., Optimization of mine ventilation fan speeds according to ventilation on demand and time of use tariff. *Applied Energy*, 146, pp. 65-73, 2015.
- [6] De Souza, E., Improving the energy efficiency of mine fan assemblages. *Applied Thermal Engineering*, 90, pp. 1092-1097, 2015.
- [7] Auld, G., An estimation of fan performance for leaky ventilation ducts. *Tunnelling and Underground Space Technology*, 19(6), pp. 539-549, 2004.
- [8] Wallace, K., Prosser, B. and Stinnette, J.D., The practice of mine ventilation engineering. *International Journal of Mining Science and Technology*, 25(2), pp. 165-169, 2015.
- [9] Yunfeng, X., Chengwu, L. and Huang, H., Study on ventilators monitoring and early fault warning system in non-coal mines. *Procedia Engineering*, 26, pp. 2239-2245, 2011.
- [10] Castro, Y., Becerra, A., Ardila, M. and Nercy, H., Optimizing a testing bank, used for evaluating performance of fans used in underground mines. *Proceedings of the 4th International Congress on Automation in Mining automining 2014*, Viña del mar Chile, 2014.
- [11] República de Colombia. Ministerio de Minas y Energía. *Reglamento de seguridad en las labores subterráneas*, 2015.
- [12] Klopfenstein, R., Air velocity and flow measurement using a Pitot tube. *ISA Transactions*, 37(4), pp. 257-263, 1998.
- [13] Shim, G., Song, L. and Wang, G., Comparison of different fan control strategies on a variable air volume systems through simulations and experiments. *Building and Environment*, 72, pp. 212-222, 2014.
- [14] Vutukuri, V.S., Uncontrolled recirculation in auxiliary ventilation with fans in series along the duct. *Mining Science and Technology*, 5(3), pp. 287-297, 1987.
- [15] MacPherson, M.J., *Subsurface ventilation and environmental engineering*. Springer; Softcover reprint of the original 1st ed. 1993, 2012, 905 P.

Y. Castro-Duque, is MSc. in Environmental Engineering, from the University of Pamplona, Colombia, in 2013. Sp. in Environmental Management Engineering, from the Universidad Francisco de Paula Santander, U.F.P.S., Colombia, in 2000, and The BSc. in Mines Eng., from the Pedagogical and Technological University of Colombia, U.P.T.C. Is Professor assigned to the Department of Geotechnics and Mining of the UFPS. Member of the Ceramic Technology Research Group (GITEC). Speaker at national and international events. He has several publications in journals and in conference proceedings.
ORCID: 0000-0002-8917-8133



UNIVERSIDAD NACIONAL DE COLOMBIA

SEDE MEDELLÍN
FACULTAD DE MINAS

Área Curricular de Ingeniería
Geológica e Ingeniería de Minas y Metalurgia

Oferta de Posgrados

Especialización en Materiales y Procesos
Maestría en Ingeniería - Materiales y Procesos
Maestría en Ingeniería - Recursos Minerales
Doctorado en Ingeniería - Ciencia y Tecnología de
Materiales

Mayor información:

E-mail: acgeom_in_med@unal.edu.co
Teléfono: (57-4) 425 53 68